

# Data Sheet



Article number: 201355106

Description: E+G Klee vertical clamp  
GN 820.1-230-N forked clamping arm

## Measures

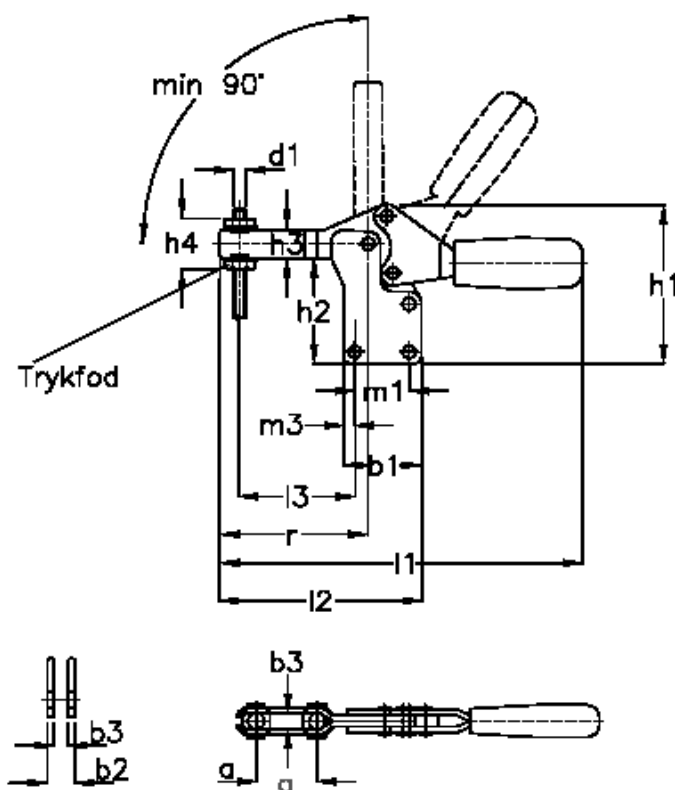

a = 37	h2 = 50.0	m2 = 6.8
b1 = 44	h3 = 18	m3 = 9.0
b2 = 12	h4 = 35	r = 72.0
b3 = 6	Holding force N = 1700	s = 6
b4 = 8.5	l1 = 196	Size = 200
d1 = M8	l2 = 109	
d2 = 6.5	l3 = 63.5	
h1 = 75.0	m1 = 26.0	